

USES

Lifting of products with parallel sides made of various materials such as wood, concrete, steel, plastic, rock, rubber, foam, cardboard boxes.

PB



PB/PU

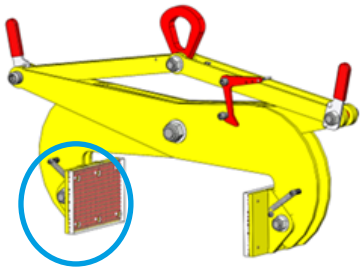

PB/PO

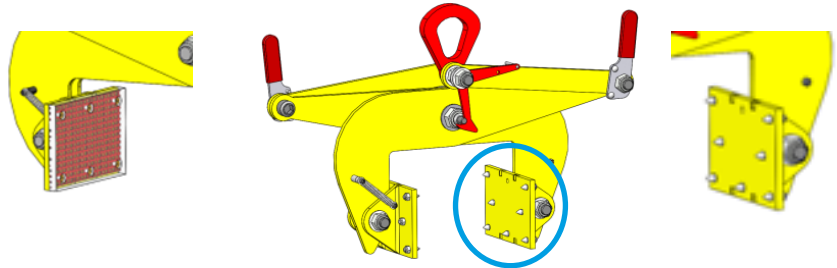

PB/MG

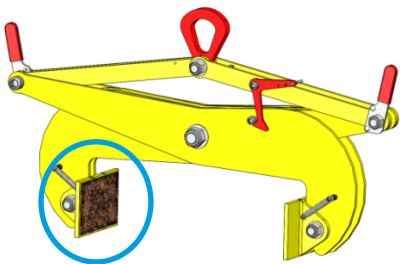

PBA

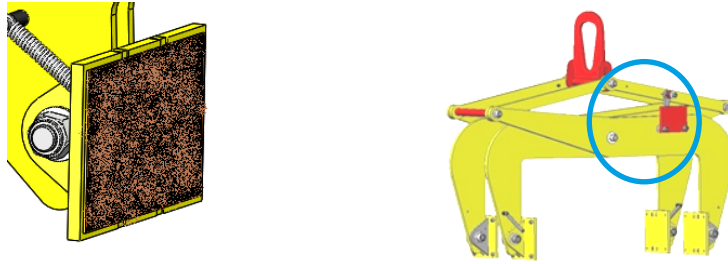

PB05

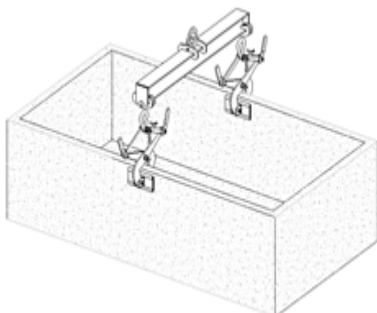

PB1

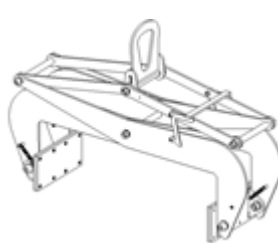

PB3

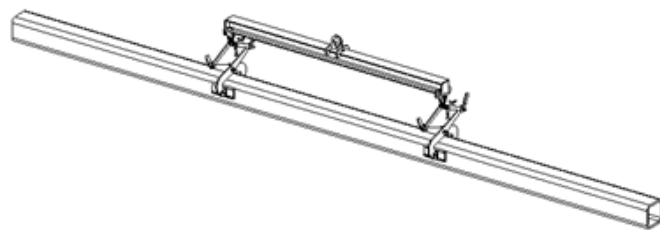
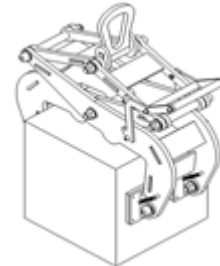

DESCRIPTION

- Clamp fitted with either:
 - a semi-automatic system which allows the load to be set down without human intervention
 - automatic system which allows the load to be picked up and set down without human intervention

PB → Semi-automatic

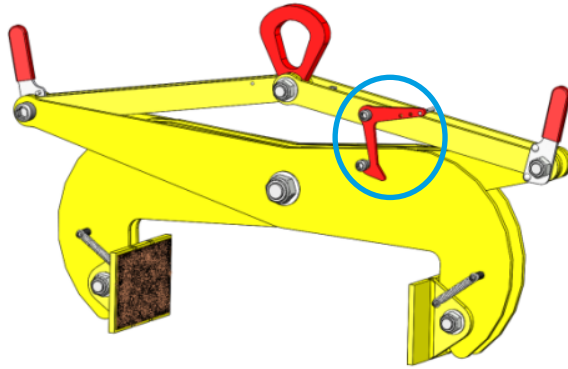

PB /A → automatic

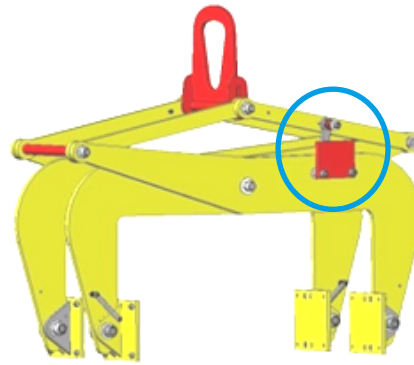

- The pads are hinged and available in different versions, see table below

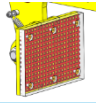
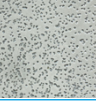
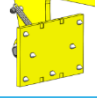
Pads			Load					
			Abrasive	Fragile	Hard ¹	Medium ²	Soft ³	
PVC or CR "Standard"		Non-marking	Not recommended → pad wear					
PU "PU"								
Grained "MG"		Marking		Not recommended → scratches on the load				
Spiked "PO"								

SPECIAL INSTRUCTIONS

- **PB & PB / PU**
 - Ensure the pads are free from grease or oil.
 - Do not lift greasy or oily parts, or parts with a smooth surface (e.g. polished marble).
 - The rubber-coated pads are suitable for most uses. However, always ensure there is good grip before lifting
- Only lift one load at a time.
- Do not lift blocks of a size that exceeds the opening capacity of the clamp used.
- The minimum weight of the load to be lifted should be equal to 5% of the clamp's WLL (e.g. if the WLL of the clamp is 1,000 kg, then minimum weight is 50 kg). This value is applicable for a clamp in perfect working order and conditions of use that comply with the recommendations of Tractel Solutions. Consult Tractel in case of loads weighing below the minimum recommended value.
- Lifting clamps are not suitable for creating permanent fixtures.
- Working temperature: -20° to +90°C.
- Contact us for any specific requests

¹ Stone, concrete, metal.

² Wood, plastic.

³ Rubber, foam, cardboard.

OPERATING INSTRUCTIONS
PB

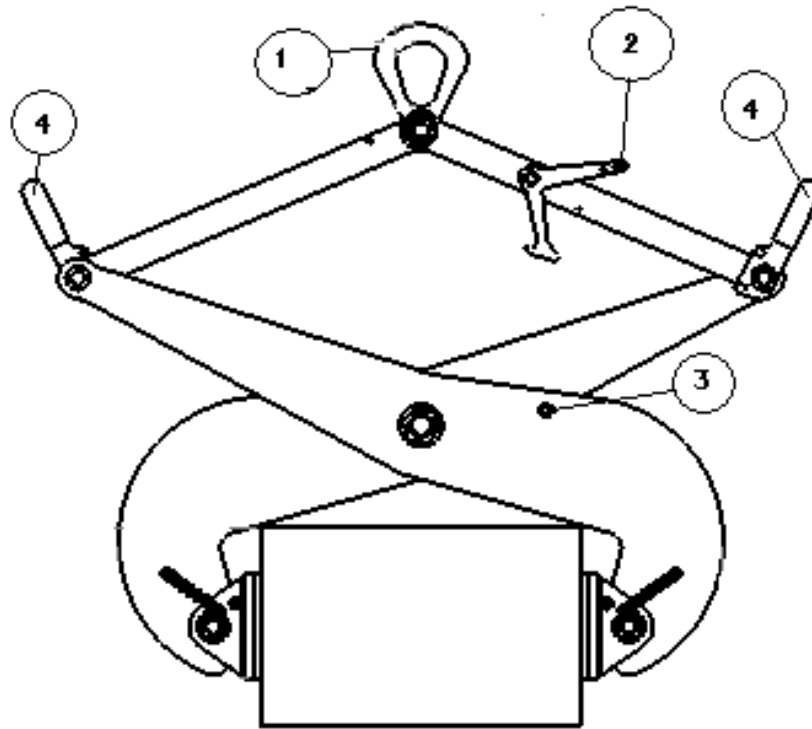

- Installation: with the clamp in a stable position, suspend it by its ring (1) from a suitable hook or sling, in the locked open position (retaining hook (2) engaged or automatic system locked).
- For lifting: position the clamp vertically over the part to be lifted.
- Lower the clamp until it comes into contact with the part to be lifted, with the pads facing the areas to be clamped on the load, making sure that the clamp always remains in a vertical position.
- **PB**
 - Swivel the retaining hook (2) by hand and, while starting to lift, hold it in the raised position to prevent it from engaging on the hook bolt (3).
 - Release the retaining hook (2) once the claw is above the hook bolt (3) and lift the load a few centimeters away from its support surface.
- **PB / A**
 - Lift back up, the automatic system unlocks the clamp
- Stop lifting and systematically check that the load is stable and securely held in the clamp before proceeding to the next step. If the load begins to slide or tilt, immediately place the load on its supports.
- Resume lifting, avoiding jolts and guiding the load only using a handle on the clamp (4).
- When setting down, lower until the load is placed on a stable support. Check the stability of the load, then resume lowering the clamp.
- **PB**
 - Lower until the retaining hook (2) automatically engages on the hook bolt (3).
- **PB / A**
 - Lower until the automatic system locks.
- Once the clamp is locked in the open position, it can be raised and is ready for use again.

GENERAL CHARACTERISTICS

- Manufactured without load-bearing welds.
- Hot epoxy coating.
- Safety factor: 3 in accordance with the EN 13155.2003 standard.
- Product conforms to the French regulation, in particular the decree of 01/03/2004 relating to the control of lifting equipment and the European Directive n° 2006/42/CE.
- Product with CE marking, delivered with a declaration of conformity and instructions for use.

RANGE

Reference Group code		Pads			
WLL kg	Automatic grip mechanism	PVC (Standard)	PU	Spiked	Grained
500	No	PB05 0-100 50458	PB05 0-100 / PU 189528	PB05 0-100 / PO 189598	PB05 0-100 / MG 189668
	Yes	PB05 0-100 / A 189458	PB05 0-100 / APU 191928	PB05 0-100 / APO 191998	PB05 0-100 / AMG 192068
	No	PB05 100-250 50468	PB05 100-250 / PU 189538	PB05 100-250 / PO 189608	PB05 100-250 / MG 189678
	Yes	PB05 100-250 / A 189468	PB05 100-250 / APU 191938	PB05 100-250 / APO 192008	PB05 100-250 / AMG 192078
	No	PB05 200-500 50478	PB05 200-500 / PU 189548	PB05 200-500 / PO 189618	PB05 200-500 / MG 189688
	Yes	PB05 200-500 / A 189478	PB05 200-500 / APU 191948	PB05 200-500 / APO 192018	PB05 200-500 / AMG 192088
1000	No	PB1 0-200 50488	PB1 0-200 / PU 189558	PB1 0-200 / PO 189628	PB1 0-200 / MG 189698
	Yes	PB1 0-200 / A 189488	PB1 0-200 / APU 191958	PB1 0-200 / APO 192028	PB1 0-200 / AMG 192098
	No	PB1 200-500 50498	PB1 200-500 / PU 189568	PB1 200-500 / PO 189638	PB1 200-500 / MG 189708
	Yes	PB1 200-500 / A 189498	PB1 200-500 / APU 191968	PB1 200-500 / APO 192038	PB1 200-500 / AMG 192108
	No	PB1 500-800 50508	PB1 500-800 / PU 189578	PB1 500-800 / PO 189648	PB1 500-800 / MG 189718
	Yes	PB1 500-800 / A 189508	PB1 500-800 / APU 191978	PB1 500-800 / APO 192048	PB1 500-800 / AMG 192118
	No	PB1 700-1000 50518	PB1 700-1000 / PU 189588	PB1 700-1000 / PO 189658	PB1 700-1000 / MG 189728
	Yes	PB1 700-1000 / A 189518	PB1 700-1000 / APU 191988	PB1 700-1000 / APO 192058	PB1 700-1000 / AMG 192128
3000	No	/	PB3 200-500 / PU 88368	/	/
	Yes	/	PB3 200-500 / APU 192528	/	/
	No	/	PB3 500-800 / PU 88378	/	/
	Yes	/	PB3 500-800 / APU 192538	/	/

TECHNICAL CHARACTERISTICS

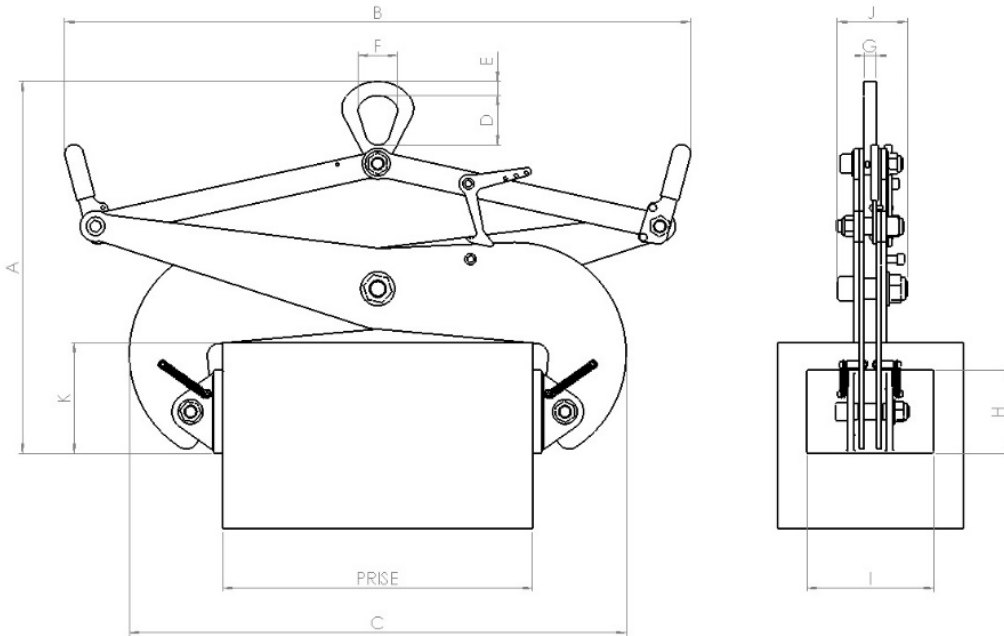

Ref	/A	/MG /AMG	/PO /APO	/PU /APU	WLL kg	Dimensions in mm														
						A		B		C		D	E	F	G	H	I	J	K	
						Min	Max	Min	Max	Min	Max								Min	Max
PB05 0-100	X	X	X	X	500	320	551	525	545	236	295	69	18	52	16	96	200	95	118	150
PB05 100-250	X	X	X	X	500	340	684	575	590	345	450	69	18	52	16	96	200	95	113	127
PB05 200-500	X	X	X	X	500	464	1031	823	870	578	735	80	23	64	20	96	200	95	203	261
PB1 0-200	X	X	X	X	1000	459	837	750	765	392	510	80	23	64	20	130	200	125	190	240
PB1 200-500	X	X	X	X	1000	550	1160	870	1010	635	830	80	23	64	20	130	200	123	175	240
PB1 500-800	X	X	X	X	1000	781	1370	1045	1080	1003	1145	170	38	110	10	150	300	289	287	337
PB1 700-1000	X	X	X	X	1000	915	1481	1162	1185	1205	1330	170	38	110	10	150	300	286	364	407
PB3 200-500				X	3000	888	1237	780	797	743	890	170	38	110	20	150	389	334	302	364
PB3 500-800				X	3000	1025	1462	1018	1085	1057	1200	170	38	110	20	150	389	334	318	377

Ref	/A	/MG /AMG	/PO /APO	/PU /APU	Weight kg	Dimensions in mm	
						Opening	
PB05 0-100	X		X		9	0	100
		X		X	10		
PB05 100-250	X		X		11	100	250
		X		X	12		
PB05 200-500	X		X		18	200	500
		X		X	19		
PB1 0-200	X		X		23	0	200
		X			25		
				X	24		
PB1 200-500	X		X		46	200	500
		X			48		
				X	47		
PB1 500-800	X		X		71	500	800
		X			75		
				X	73		
PB1 700-1000	X		X		95	700	1000
		X			99		
				X	97		
PB3 200-500				X	130	200	500
PB3 500-800				X	177	500	800